

# Curaflex® F

PRESSING WATER

- Sealing of penetrations
- Use in **on-site pipe sleeve** or **waterproof concrete core bore** (white tank)
- with **additional large ring** for **axial mounting**
- For **high hydrostatic pressure**

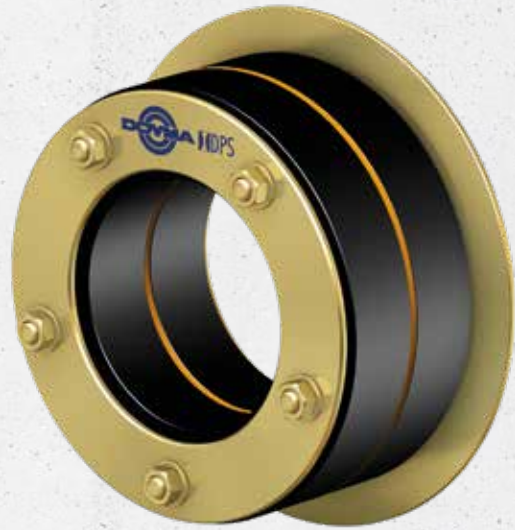

DOYMA GRIP

DPS



25 years guarantee

## PRODUCT ADVANTAGES

- Large sealing areas
- Permanently sealed – no need to re-tension later (maintenance-free)
- Greater sealing performance of the gasket insert thanks to DPS and DOYMA-Grip
- System component, without cuts or divisions, with water-tight welded bolts
- The large ring allows for secure mounting – including for high pressure
- Mounting from the non-pressure-facing side

## TECHNICAL DETAILS

- Certified under FHRK test regulation GE 101 (no. G 30 322-2-2) - FHRK 57 LD10
- Gas and water-tight
- Radon-tight – according to FHRK information sheet MB101 meets the requirements for radon precautionary areas
- Bending of medium pipes up to 8° is possible
- Can accommodate axial movements
- Twin sealing, with large ring

## THE GASKET INSERT CONSISTS OF:

- **Frame rings:** asymmetrically profiled steel rings (DPS to KB/DN 350), GGV triple corrosion protection coating; optionally made of stainless steel 1.4301 (V2A) or 1.4571/1.4404 (V4A)
- **Rubber seal:** elastomer, 2 × 27 mm thick EPDM seals (DOYMA-Grip), optional EPDM-TW, NBR (fuel/oil-resistant) or silicone (high temperature-resistant) or FPM (chemical-resistant)
- 3 mm thick orange centre ring (up to KB/DN 350)



Variant: Curaflex® D – properties as described above, but with mounting from the pressure-facing side ('water side').

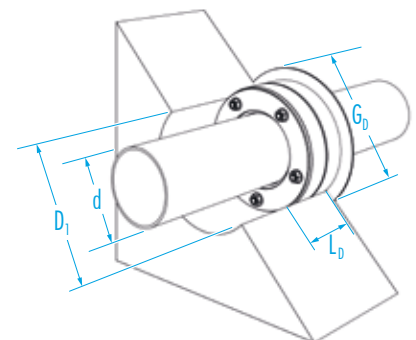

### ACCESSORIES (OPTIONAL)\*

- Aquagard core bore sealant

\* see corresponding section

## Curaflex® F

Outer diameter of pipe / cable d [mm]	Inner diameter of pipe sleeve / core bore D <sub>i</sub> [DN in mm]	Outer diameter of large ring G <sub>o</sub> max. [mm]
7 – 24	50 (49 – 53)	70
7 – 40	80 (79 – 83)	98
41 – 57	100 (99 – 104)	120
58 – 77	125 (124 – 128)	145
78 – 104	150 (149 – 153)	170
105 – 145	200 (199 – 204)	240
146 – 190	250 (247 – 253)	290
191 – 233	300 (297 – 304)	340
234 – 288	350 (347 – 354)	390
289 – 339	400 (397 – 404)	440
340 – 380	450 (447 – 454)	490
381 – 430	500 (497 – 503)	550
431 – 530	600 (597 – 603)	650
531 – 620	700 (697 – 703)	750

L<sub>0</sub> (max. design depth) [mm]: 95

Further dimensions available upon request.